

THE **ADJUSTABLE DECK JET 1" G SS** IS A FLUSH MOUNT, STAINLESS STEEL NOZZLE THAT SPRAYS A SOLID STREAM OF WATER. THE ANGLE OF THE STREAM IS ADJUSTABLE.



801-837-2199
sapphirefountains.com

SPECIFICATIONS

- DIMENSIONS - SEE BELOW (FOR GENERAL FIT PURPOSES ONLY)
- PIPE THREAD: 1" G (BPSS). ADAPTER SHOWN BELOW AVAILABLE FOR 1" NPT APPLICATIONS
- APPROXIMATE SPRAY HEIGHTS

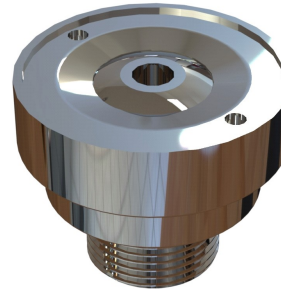

SPRAY HEIGHT (FT)	FLOW RATE (GPM)	PRESSURE (FT OF HEAD)
2	4	3.5
3	5	4.5
4	6	7
5	6.5	8
6	7	9
7	7.5	10.5
8	8	11.5

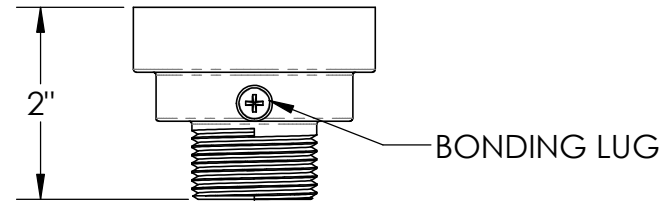
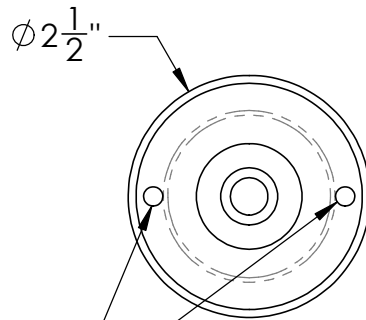

ADAPTER FOR NPT PIPE THREAD

RECOMMENDED FITTING: PDT-0251

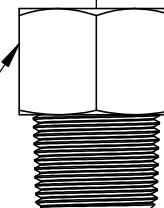

DESCRIPTION

DECK JET, ADJUSTABLE, 1 G SS

PROPRIETARY & CONFIDENTIAL

THE INFORMATION CONTAINED IN THIS DRAWING IS THE SOLE PROPERTY OF SAPPHERE FOUNTAINS LLC. ANY REPRODUCTION IN PART OR AS A WHOLE WITHOUT WRITTEN PERMISSION OF SAPPHERE FOUNTAINS IS PROHIBITED.

PART NUMBER

PDT-0151

REV A

DIMENSIONS ARE IN INCHES

SHEET 1 OF 1